

FOR RETURN

## 納入仕様書

Product Specifications

 新規 (部品追加を含む)

New application (Including addition to approved parts)

貴社部品名

Customer's parts Name

 仕様変更 (「貴社」納入者)

Specification revision「」 by customer of「」 by supplier)

貴社部品番号

Customer's parts number

弊社部品名

Supplier's parts name

弊社部品番号 F-4992-675-0(Boat)

Supplier's parts number F-4992-676-0(Air)

【受領印欄 Received Marking】

納入者 Supplier

ソニー株式会社

コンシューマー・プロフェッショナル&amp;デバイスグループ

デバイスソリューション事業本部

Sony Corporation Consumer, Professional &amp; Devices Group

Device Solutions Business Group

〒108-0075

東京都港区港南 1-7-1

1-7-1 Konan, Minato-ku, Tokyo, 108-0075 Japan

申請年月日 2013 年 01 月 14 日

Date of application (Y/M/D)

責任者名

Manager



技術担当名

Engineer

Ono

営業担当名

Salesman

Sano

仕様書番号

Spec. No.

KU-21951

Ver.

1.0

納入仕様書
Product Specifications



貴社名 : \_\_\_\_\_  
 Customer's name

貴社部品名 : \_\_\_\_\_  
 Customer's parts name

貴社部品番号 : \_\_\_\_\_  
 Customer's parts number



ソニー部品名 : \_\_\_\_\_  
 SONY parts name

ソニー部品番号 : F-4992-675-0 (Boat)  
 SONY parts number F-4992-676-0 (Air)  
 \_\_\_\_\_

承認 Approved by	確認 Checked by	作成 Prepared by
		

変更履歴

History of revisions

変更年月日 Date		変更事項 Description	承認 Approved by	作成 Prepared by
Ver.1.0	2012. 12.18	1 <sup>ST</sup> issue		

## Contents

1. General .....	4
1.1 Scope .....	4
1.2 Product Category.....	4
1.3 Cell Type.....	4
1.4 Applicable Safety Standard.....	4
2. Cell Rating .....	
2.1 Nominal Capacity .....	4
2.2 Rated Capacity.....	4
2.3 Nominal Voltage.....	4
2.4 Charge Voltage .....	4
2.5 Cut Off Voltage .....	4
2.6 Maximum Charge Voltage.....	4
2.7 Continuous Maximum Charge Current.....	4
2.8 Continuous Maximum Discharge Current.....	4
2.9 Weight.....	4
2.10 Allowable Environment Temperature.....	4
2.11 Energy Density .....	4
2.12 Charge Conditions.....	5
3. Shape / Dimension and Appearance.....	5
3.1 Shape/Dimension.....	5
3.2 Appearance.....	5
4. Performance.....	5
4.1 Standard Test Condition.....	5
4.2 Testing Instrument or Apparatus .....	5
4.3 Standard Charge definition.....	5
4.4 Standard Discharge definition.....	5
4.5 Electrical Performance.....	6~7
4.6 Mechanical Performance.....	7
5. Identification and Marking.....	8
5.1 Manufacturer Name.....	8
5.2 Trade Mark .....	8
5.3 Plant.....	8
5.4 Specification .....	8
5.5 Lot Number.....	8
5.6 UL Marking.....	8
5.7 Korean Regulation.....	8
5.8 2Dimensional Code.....	8
6. Caution.....	8
6.1 Caution for installing the battery into the pack.....	8
6.2 Caution for the battery and the pack.....	8~9
6.3 Storage.....	9
6.4 Prohibition Clause.....	10
7. Outline .....	10
8. Packing.....	11
8.1 Packing Instruction.....	11
8.2 Printing Instruction for Master Carton.....	12
8.3 Parts name marking.....	13
8.4 Packing Instruction for Pallet .....	14

## Lithium-Ion Battery Specifications

## 1. General

## 1.1 Scope

This specification is applied to Lithium-Ion Rechargeable Battery provided by Sony.

1.2 Product Category: Lithium-Ion Rechargeable Battery

1.3 Cell Type US18650NC1

1.4 Acquired Safety Standard Approval UL1642: File No.MH12566  
IEC62133 (INR19/66)

## 2. Cell Rating

Item	Rating	Note
2.1 Nominal Capacity	2900mAh	Discharge at 0.2ItA, 2.5V cutoff after Standard Charge
2.2 Rated Capacity	2750mAh	Discharge at 0.2ItA, 2.5V cutoff after Standard Charge
2.3 Nominal Voltage	3.6V	
2.4 Charge Voltage	4.20 +/- 0.05V	
2.5 Cut Off Voltage	2.5V	
2.6 Maximum Charge Voltage	4.25V	
2.7 Maximum Charge Current	3A	
2.8 Continuous Maximum Discharge Current	8A	
2.9 Weight	45.3 +/- 1.5g	
2.10.1 Allowable Environment Temperature	Charge	0 to +45degC
	Discharge	-20 to +60degC
2.10.2 limit of cell surface temperature	Charge	60deg.C
	Discharge	80deg.C
2.11 Energy Density	588Wh/l	In case of over 400Wh/l, it is possibility to be subject to regulation by object country.

<Note> The cells must not be discharged when the environmental temperature is outside of the range of -20°C to 60°C. For discharging, it is acceptable for the cell surface temperature to rise to 80°C at maximum points.

※ Cell condition at the shipment ; About 70% discharged.

2.12 Charge Conditions					
Temperature Range			Upper Limited Charging Voltage	Maximum Charging Current	Charging Current Recommendation
1	Low Charging Temperature Range	$0^{\circ}\text{C} \leq T < 10^{\circ}\text{C}$	4.25V	1.5A	0.963A
			4.15V	3A	1.925A
2	Standard Charging Temperature Range	$10^{\circ}\text{C} \leq T < 45^{\circ}\text{C}$	4.25V	3A	1.925A
3	High Charging Temperature Range	$45^{\circ}\text{C} < T \leq 60^{\circ}\text{C}$	4.15V	3A	1.925A

3. Shape/Dimension and Appearance

3.1 Shape/Dimension (Ref. P10 7. Outline)

Diameter of crimp	18.2 +0.15 / -0.2mm
Diameter of trunk	18.2 +0.15 / - 0.2 mm (excluding wrinkle on the tube)
Total Length	65.00 +/- 0.2mm

3.2 Appearance

There shall be no remarkable scratches, stains, deformation, or leakage that could affect quality or reliability. Any uncertainty arising out of this phrase shall be settled upon consultation between both parties.

4. Performance

4.1 Standard Test Condition

Test condition shall be at 23 +/- 2degC and 65 +/- 20% R.H.

4.2 Testing Instrument or Apparatus

4.2.1 Dimension Measuring Instrument

The dimension measurement shall be implemented by instruments with equal or more precision scale of 0.01mm specified by JIS B 7502(outside micrometer) or JIS B 7503(dial gauge).

4.2.2 Voltmeter and Ammeter

Voltmeters and ammeters shall be equal or more precision instruments specified by JIS C 1102 (Indication Electric Instrument Level 0.5).

4.2.3 Impedance Meter

Impedance shall be measured by a sinusoidal alternating current method (1kHz LCR meter).

4.3 Standard Charge definition

Charging at a constant voltage of 4.2V and a constant current of 1.925A for 3.0 hours in 23±2°C atmosphere.

4.4 Standard Discharge definition

Discharging at a constant current of 2.75A down to 2.5V in 23±2°C atmosphere.

(Y/15)

4.5 Electrical Performance

Item	Condition	Specification										
4.5.1 Open-Circuit Voltage	Shipping condition	3.40-3.80V and the OCV shall be within 0.1V on the same cell lot.										
4.5.2 AC Impedance	After standard charge within 3 days.(1kHz)	18-28mohm										
4.5.3.1 Capacity	After standard discharging. Discharge at 0.2ItA(550mA) cut off voltage 2.5V	2750mAh or more										
4.5.3.2 Capacity(2)	After standard charging, Standard discharging	2613mAh or more										
4.5.3.3 Capacity(3)	After standard charging, Discharge at 6A cut off voltage 2.5V	2475mAh or more										
4.5.3.4 Capacity(4)	After standard charging, Discharge at 8A cut off voltage 2.5V	2200mAh or more										
4.5.4 Charge/Discharge Cycle	After charging 4.2V, 1A, 100mA cut off ↔ Discharge at 6A, cut off voltage 2.5V after 100 cycles	1925mAh or more										
4.5.5 Discharging Temperature Characteristic	After standard charging, Discharge at 6A, 2.5V cut off under the following ambient temperature <table border="1" data-bbox="582 1086 1157 1310"> <thead> <tr> <th>Discharge Temperature</th> <th>Capacity</th> </tr> </thead> <tbody> <tr> <td>-10degC</td> <td>1733mAh or more</td> </tr> <tr> <td>0degC</td> <td>1980mAh or more</td> </tr> <tr> <td>23degC</td> <td>2475mAh or more</td> </tr> <tr> <td>45degC</td> <td>2475mAh or more</td> </tr> </tbody> </table>	Discharge Temperature	Capacity	-10degC	1733mAh or more	0degC	1980mAh or more	23degC	2475mAh or more	45degC	2475mAh or more	Refer to the left table.
Discharge Temperature	Capacity											
-10degC	1733mAh or more											
0degC	1980mAh or more											
23degC	2475mAh or more											
45degC	2475mAh or more											
4.5.6 Charging Temperature Characteristic	After standard discharging, charge at 4.20V, 1.925A for 3.0 hours under the following ambient temperature. <table border="1" data-bbox="582 1456 1157 1601"> <thead> <tr> <th>Charge Temperature</th> <th>Capacity</th> </tr> </thead> <tbody> <tr> <td>0degC</td> <td>2222mAh or more</td> </tr> <tr> <td>23degC</td> <td>2613mAh or more</td> </tr> <tr> <td>45degC</td> <td>2613mAh or more</td> </tr> </tbody> </table>	Charge Temperature	Capacity	0degC	2222mAh or more	23degC	2613mAh or more	45degC	2613mAh or more	Refer to the left table		
Charge Temperature	Capacity											
0degC	2222mAh or more											
23degC	2613mAh or more											
45degC	2613mAh or more											
4.5.7.1 Storage Characteristic(1)	After standard charging, stored at 23 degC for 28 days. Remaining capacity from 6A (2.5V cut off) discharging.	2228mAh or more										
4.5.7.2 Storage Characteristic(2)	After above measurement, Recovery capacity by discharge at 6A, 2.5V cutoff after standard charge.	2352mAh or more										
4.5.7.3 Storage Characteristic(3)	After standard charging, stored at 45 degC for 28 days. Remaining capacity from 6A (2.5V cut off) discharging.	2104mAh or more										

4.5.7.4 Storage Characteristic(4)	After above measurement, Recovery capacity by discharge at 6A, 2.5V cutoff after standard charge.	2228mAh or more
4.5.8 Long term Storage characteristic	After standard Charging, store at 23 degC, 365days. Recovery capacity of standard charging and 6A(2.5V cut off) discharging.	2228mAh or more

## 4.6 Mechanical Performance

Item	Condition	Specification
4.6.1 Heat cycle test	1) Standard charge 2) Heat cycle at 75°C6h←30min→-40°C6h for 10 cycles. 3) Storage at 20±5°C for 24hours	No leakage, No interception
4.6.2 Shock test	1) Standard Charge 2) Drop the battery from 1.2m height onto P-tile for 3 times in each of X, Y and Z direction 3) Discharge at 6A, 2.5V cutoff 4) Standard charge 5) Capacity by discharge at 6A, 2.5V cutoff	No leakage 2352mAh or more
4.6.3 Vibration test	1) Standard charge 2) Vibration test under the following condition Frequency and acceleration:10~60Hz, 20.6m/s <sup>2</sup> Frequency and acceleration:60~80Hz, 13.7m/s <sup>2</sup> Frequency and acceleration:80~100Hz, 6.9m/s <sup>2</sup> Frequency and acceleration:100~125Hz, 3.9m/s <sup>2</sup> 5min. sweep, 1 hour for each axes 3) Discharge at 6A, 2.5V cutoff 4) Standard charge 5) Capacity by discharge at 6A, 2.5V cutoff	No leakage. 2352mAh or more



5. Identification and Marking (Lot Number Definition: Manufacturing Date of Cells)

The code is printed on a surface of the can, under the tube, at three lines.

5.1 Manufacturer Name (Trade name)  
SE (Trade name of Sony Energy Devices Corp.)

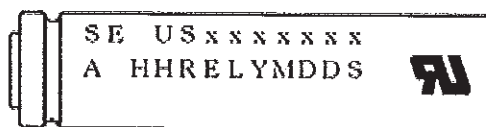

Fig.1

5.2 Trade Mark (Fig.1:USxxxxxx)  
US18650NC1

5.3 Plant (Fig.1:A for plant code)  
K: Sony Energy Devices Corp. Koriyama Plant. T: Sony Energy Devices Corp. Tochigi Plant.  
SG or G: Sony Electronics (Singapore)

5.4 Specification (Fig.1.:HH for Cell Type)  
1N: US18650NC1

5.5 Lot Number (Fig.1 : YMDDS for Manufacturing Date of Cells)  
Y:Year '92 as A, Every next year is counted as B, C,... (Using an Alphabet letter)  
M:Month January as A, the consecutive month as B, C,... (Using an Alphabet letter)  
D:Day 01, 02, ....29,30,31 (Using figures)  
S:Electrode History A,B,C,.. (Using an Alphabet letter)

5.6 UL Marking  
Recognition Mark on the right side of Fig.1

5.7 2Dimensional Code (Fig.2)  
The code is on the surface of the tube



Fig.2

6. Caution

Caution on usage of Lithium-Ion Rechargeable Battery.

6.1 Caution for installing the battery into the pack  
\*Do not combine the different Lot Number cell (the Last 5 letters and figure) into the pack

6.2 Caution for the battery and the pack

6.2.1 Charge

\*It shall be Constant Current-Constant Voltage (CC-CV) charging method.

6.2.2 Discharge

\*It shall avoid less than 2.5V by discharging.

6.2.3 Design of battery pack

\*It shall be the shape which cannot be connected easily to any charger other than the dedicated charger.

\*It shall have the structure which cannot be connected easily for end user to apply for the other purpose.

\*It shall have the terminals or function which cannot easily cause external short circuit (such as chain short by necklace).

\*It shall not be short easily by effect of vibration or drop due to contact of internal writing materials to battery.

### 6.2.4 Protection Circuit

\*The protection circuit shall be installed in the battery pack, the Host or the charger.

\*The battery must possess four types of protective circuits as follows.

#### 6.2.4.1 Over charging protective circuit

The over charging protective circuit shall operate at less than 4.250V/cell by each block cell voltage monitoring.

#### 6.2.4.2 Over discharging protective circuit

The over discharging protective circuit shall operate at 2.0V/cell to 2.5V/cell.

(In case of -10~-20deg.C, the circuit shall operate at 1.5V/cell to 2.5V/cell)

#### 6.2.4.3 Over current protective circuit

The over current protective circuit shall operate charging at over 3A.

The over current protective circuit shall operate discharging over 8A.

#### 6.2.4.4 Over temperature protective circuit at cell surface temperature

The over temperature protective circuit at high temperature side shall operate discharging until 80deg.C

The over temperature protective circuit at high temperature side shall operate charging at until 60deg.C.

The over temperature protective circuit at low temperature side shall operate charging until 0deg.C.

### 6.3 Storage

\*It shall be kept in shipping condition (70% discharge) or over than 70% discharge condition to storage for long period.

\*It shall be kept in dry condition of low humidity, especially be free from high temperature (45deg.C or more).

( Recommended Temperature 20deg.C. , Humidity 50% or less. )

\*Do not storage the battery near heat sources, nor in a place subject to direct sunlight to storage in warehouse.

\*It shall be used the battery within 3 months ( 90 days ) after shipping.

### 6.4 Prohibition Clause

- \*Do not throw the battery into fire, nor heat the battery.
- \*Do not disassemble nor modify the battery.
- \*Do not leave the battery in a place of high temperature (60degC or more).
- \*Do not use the battery in a place of high temperature (60degC or more).
- \*To prevent the battery from water or moisture.
- \*Do not add strong shock, nor drop the battery.
- \*Do not solder lead directly to the battery body.
- \*Do not short (+) and (-) terminal of the battery with a kind of metal.
- \*Do not charge beyond the condition which described on the delivery specification.
- \*Do not reverse charge the battery.
- \*Do not use together with the battery of a different kind.
- \*Do not penetrate the battery with a nail etc., nor make a hole in the battery.
- \*Do not put the battery into a microwave oven, nor high pressure container.
- \*Do not connect the battery to wall sockets and cigarette wall sockets in vehicle, etc.

### 7.Outline

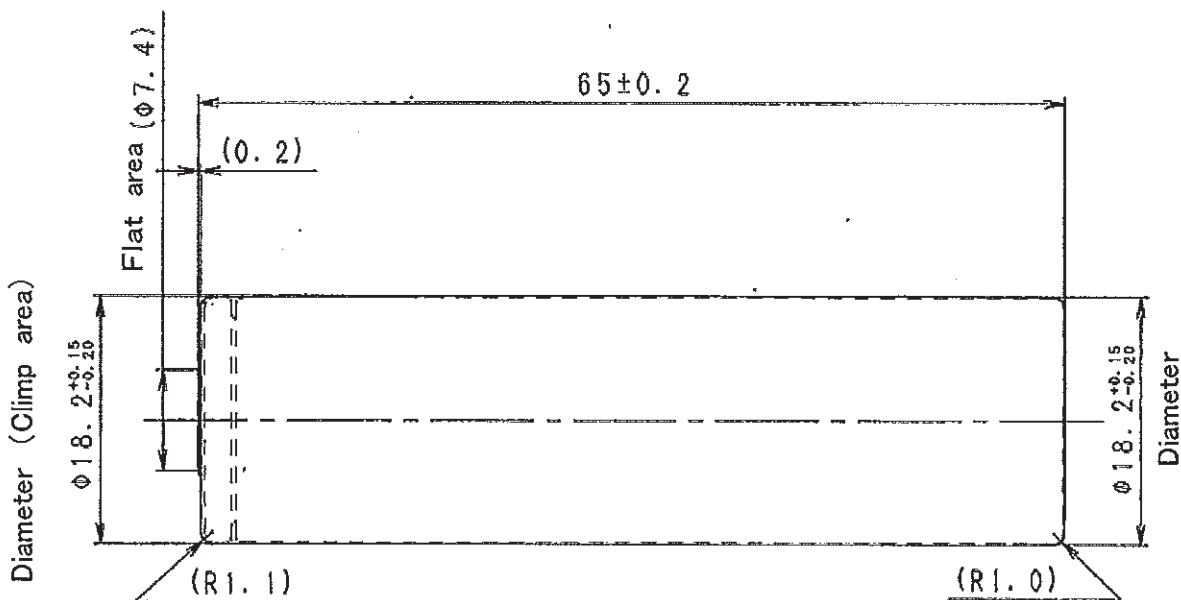

ボトム部タブ溶接禁止エリア  
 Prohibited area tab welding the bottom portin  
 右図のように、中心部からφ3の範囲は溶接しないこと  
 As shown in the figure on the right,  
 don't weld in the range of φ3 from center

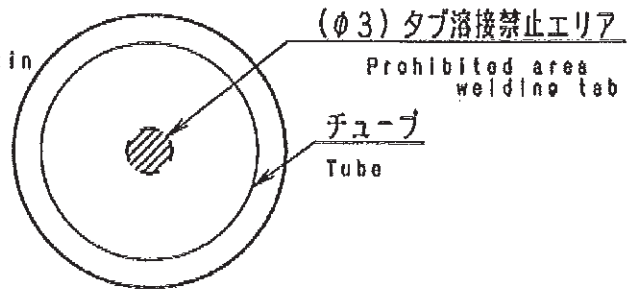

### 8. Packing

#### 8.1 Packing Instruction

##### 8.1.1 Boat transport specifications

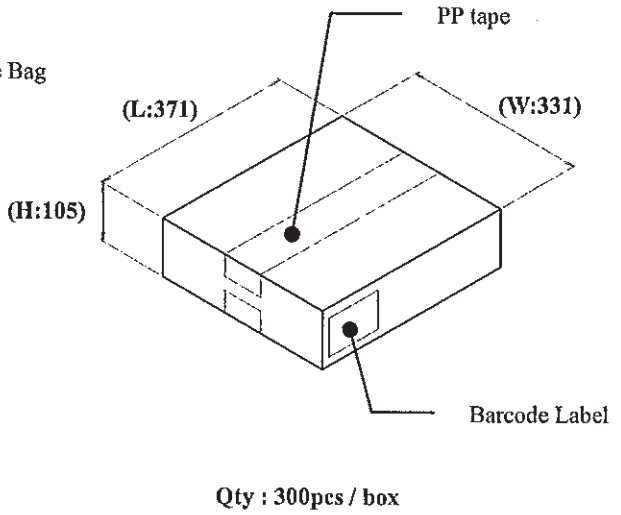
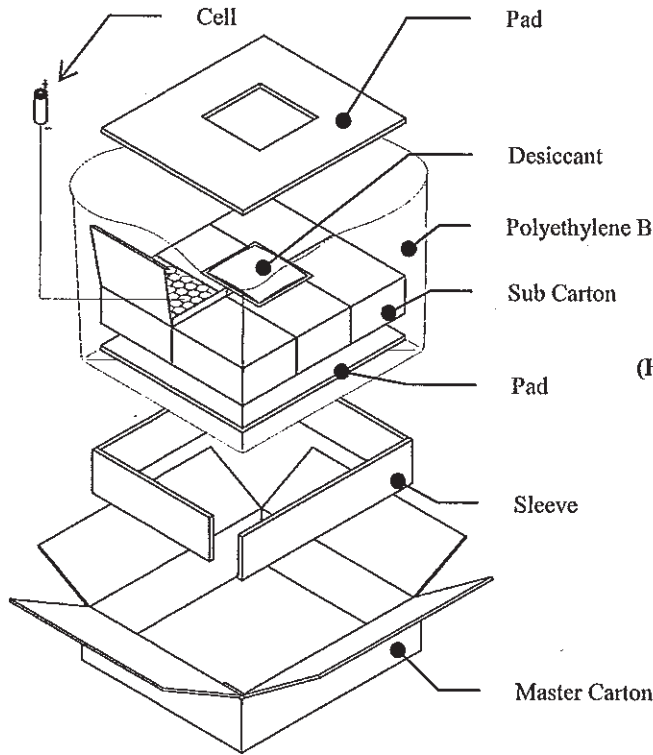

##### 8.1.2 Air transport specifications

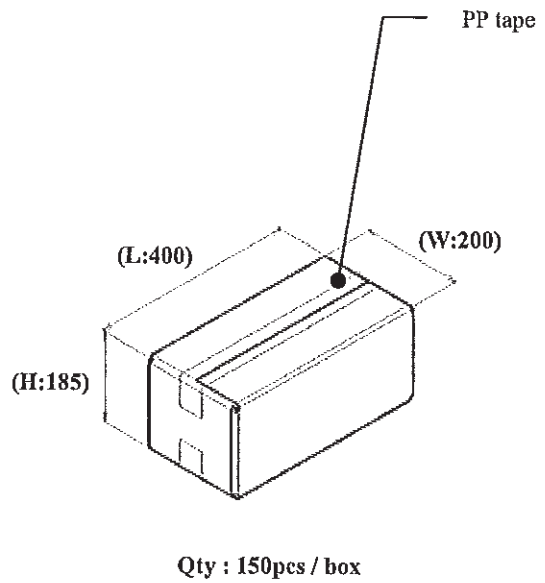
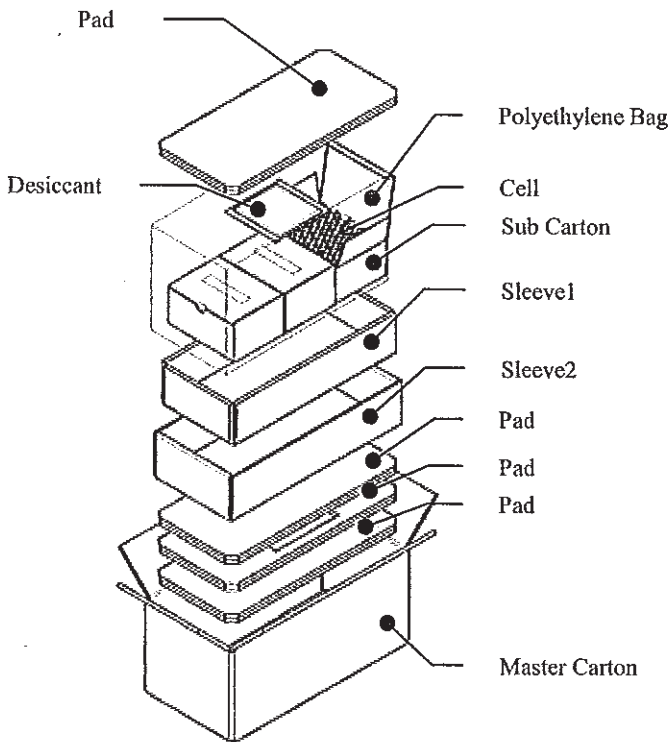

### 8.2 Printing Instruction for Master Carton

#### 8.2.1 Boat transport specifications

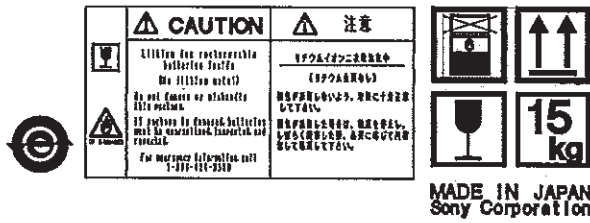
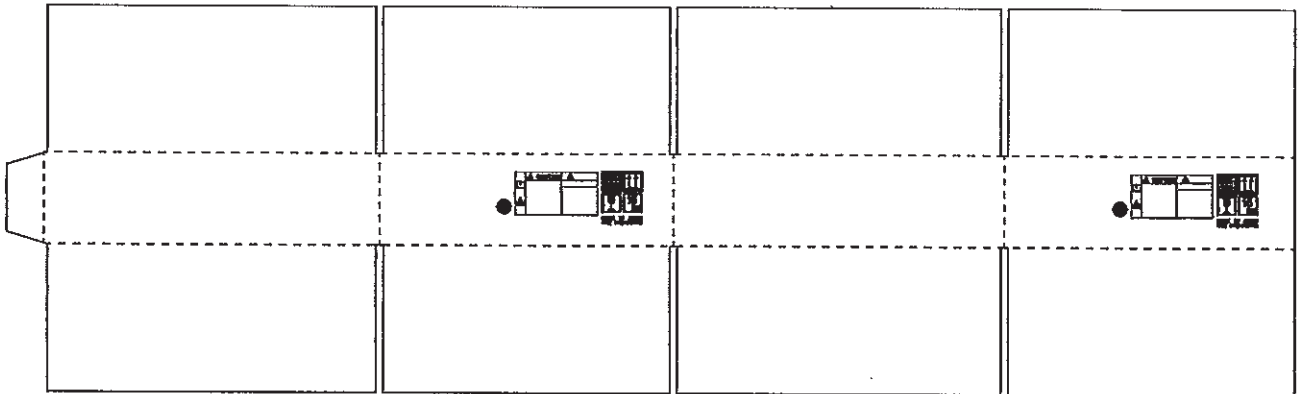

#### 8.2.1 Air transport specifications

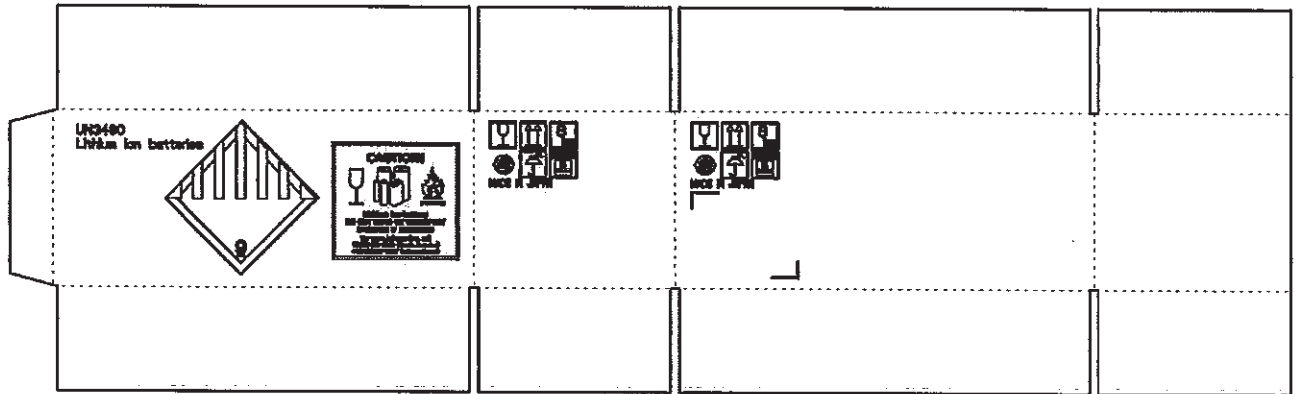

**UN3480**  
Lithium ion batteries

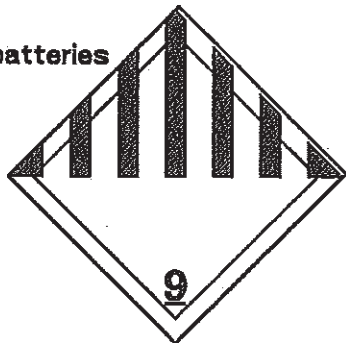

8.3 Parts name marking

8.2.1 Boat transport specifications

MODEL NAME	UST180BMNC1(AE)	MODEL CODE	
MODEL CODE	F49926750	*****	
CELL NAME	US18650NC1	CELL Lot No.	
CELL CODE	1-853-238-11	*****	
CELL Lot No.	*****	MASTER CARTON No.	
SUPPLIER	Sony Corporation	*****	
		MASTER CARTON Qty.	
		*****	
		PACKING DATE	
		*****	
		CUSTOMER CODE	
		*****	

8.2.2 Air transport specifications

MODEL NAME	UST180BMNC1(E)	MODEL CODE	
MODEL CODE	F49926760	*****	
CELL NAME	US18650NC1	CELL Lot No.	
CELL CODE	1-853-238-11	*****	
CELL Lot No.	*****	MASTER CARTON No.	
SUPPLIER	Sony Corporation	*****	
		MASTER CARTON Qty.	
		*****	
		PACKING DATE	
		*****	
		CUSTOMER CODE	
		*****	

### 8.4 Packing Instruction for Pallet

#### 8.4.1 Boat transport specifications

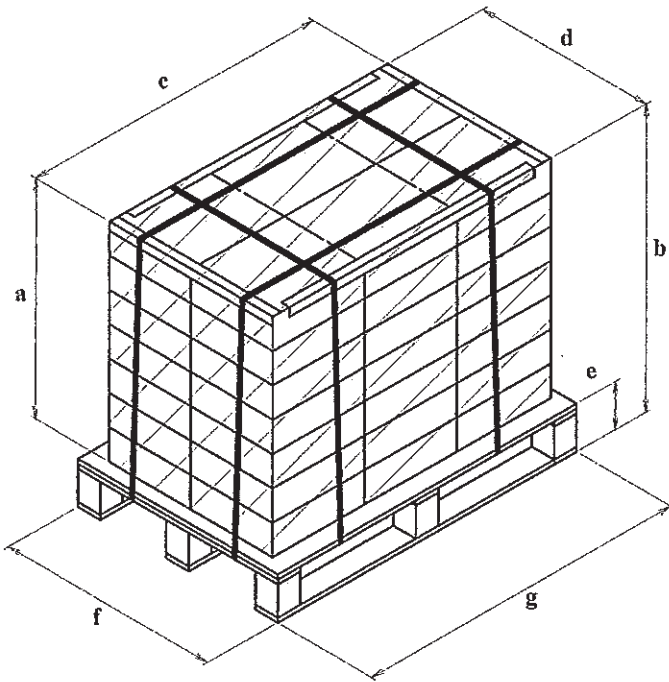

- Size (mm)
- a : 735
  - b : 865
  - c : 1113
  - d : 662
  - e : 126
  - f : 800
  - g : 1200

#### 8.4.2 Air transport specifications

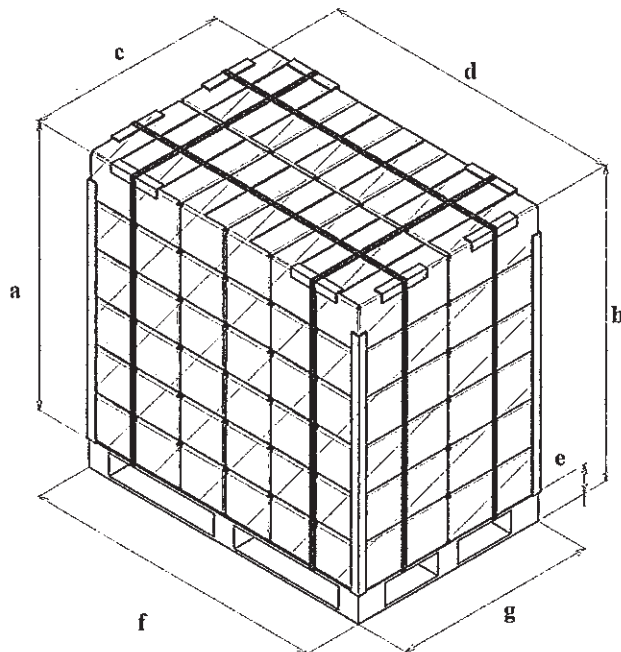

- Size (mm)
- a : 1110
  - b : 1286
  - c : 800
  - d : 1200
  - e : 126
  - f : 800
  - g : 1200

## Reference

In case of the energy density is more than 400Wh/l (see 2.11), it is possibility to be subject to regulation by object country. It is recommend to confirm the contents of regulation.

As of October 2012.

Japan, Electrical Appliance and Material Safety Law

<http://www.meti.go.jp/policy/consumer/seian/denan/index.htm>

Korea, Electrical Appliances Safety Control Act

<http://www.safetykorea.kr/>